

## TI SimpleLink™ CC3000 Module – Wi-Fi 802.11b/g Network Processor

### FEATURES

- **Wireless network processor**
  - IEEE 802.11 b/g
  - Embedded IPv4 TCP/IP stack
- **Best-in-class radio performance**
  - TX power: +18.0 dBm at 11 Mbps, CCK
  - RX sensitivity: –88 dBm, 8% PER, 11 Mbps
- **Works with low MIPS and low-cost MCUs with compact memory footprint**
- **FCC, IC, and CE certified with a chip antenna**
- **HW design files and design guide available from TI**
- **Integrated crystal and power management**
- **Small form factor: 16.3 mm × 13.5 mm × 2 mm**

- **Operating temperature: –20°C to 70°C**
- **Based on TI's seventh generation of proven Wi-Fi solutions**
- **Complete platform solution including user and porting guides, API guide, sample applications, and support community**

### APPLICATIONS

- **Home automation**
- **Home security**
- **Connected appliances**
- **Smart energy**
- **M2M communication**

### DESCRIPTION

The TI CC3000 module is a self-contained wireless network processor that simplifies the implementation of Internet connectivity (see [Figure 1](#)). TI's SimpleLink™ Wi-Fi solution minimizes the software requirements of the host microcontroller (MCU) and is thus the ideal solution for embedded applications using any low-cost and low-power MCU.

The TI CC3000 module reduces development time, lowers manufacturing costs, saves board space, eases certification, and minimizes the RF expertise required. This complete platform solution includes software drivers, sample applications, API guide, user documentation, and a world-class support community.

For more information on TI's wireless platform solutions for Wi-Fi, go to TI's Wireless Connectivity wiki ([www.ti.com/connectivitywiki](http://www.ti.com/connectivitywiki)).

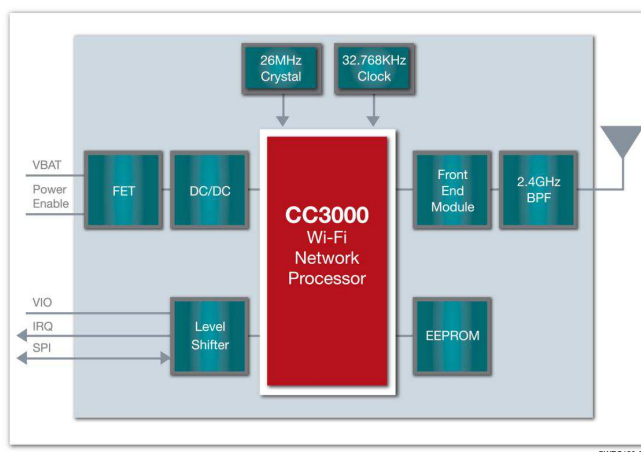

**Figure 1. Wi-Fi Solution for TI SimpleLink CC3000 Module**



Please be aware that an important notice concerning availability, standard warranty, and use in critical applications of Texas Instruments semiconductor products and disclaimers thereto appears at the end of this data sheet.

SimpleLink, Smart Config are trademarks of Texas Instruments.

Wi-Fi is a trademark of Wi-Fi Alliance.

All other trademarks are the property of their respective owners.



This integrated circuit can be damaged by ESD. Texas Instruments recommends that all integrated circuits be handled with appropriate precautions. Failure to observe proper handling and installation procedures can cause damage.

ESD damage can range from subtle performance degradation to complete device failure. Precision integrated circuits may be more susceptible to damage because very small parametric changes could cause the device not to meet its published specifications.

## FEATURES

### WLAN

- 802.11b/g integrated radio, modem, and MAC supporting WLAN communication as a BSS station with CCK and OFDM rates from 1 to 54 Mbps in the 2.4-GHz ISM band
- Auto-calibrated radio with a single-ended 50- $\Omega$  interface enables easy connection to the antenna without requiring expertise in radio circuit design.
- Advanced connection manager with seven user-configurable profiles stored in an NVMEM allows automatic fast connection to an access point without user or host intervention.
- Supports all Wi-Fi security modes for personal networks: WEP, WPA, and WPA2 with on-chip security accelerators
- Smart Config™ WLAN provisioning tools allow customers to connect a headless device to a WLAN network using a smart phone, tablet, or PC.

### Network Stack

- Integrated IPv4 TCP/IP stack with BSD socket APIs enables simple internet connectivity with any microcontroller, microprocessor, or ASIC.
- Supports four simultaneous TCP or UDP sockets
- Built-in network protocols: ARP, ICMP, DHCP client, and DNS client enable easy connection to the local network and to the Internet.

### Host Interface and Driver

- Interfaces over 4-wire serial peripheral interface (SPI) with any microcontroller, or processor at clock speed up to 16 MHz
- Low footprint driver provided for TI MCUs and easily ported to any processor or ASIC
- Simple APIs enable easy integration with any single-threaded or multi-threaded application.

### System

- Works from a single, preregulated power supply or connects directly to a battery
- Separated I/O voltage rail allows flexible integration with host processors
- Ultra-low leakage shut-down mode with current <5  $\mu$ A
- Integrated clock sources

### EEPROM

- Integrated EEPROM stores firmware patch, network configuration, and MAC address.
- Programmable through an I2C interface or over APIs from the host, allowing over-the-air firmware upgrades
- Can store 5 KB of user data accessible to the host application, enhancing the MCU NVM

**PACKAGE INFORMATION**

**Module Outline**

For the PCB layout of your applications, TI recommends the footprint shown in [Figure 2](#).

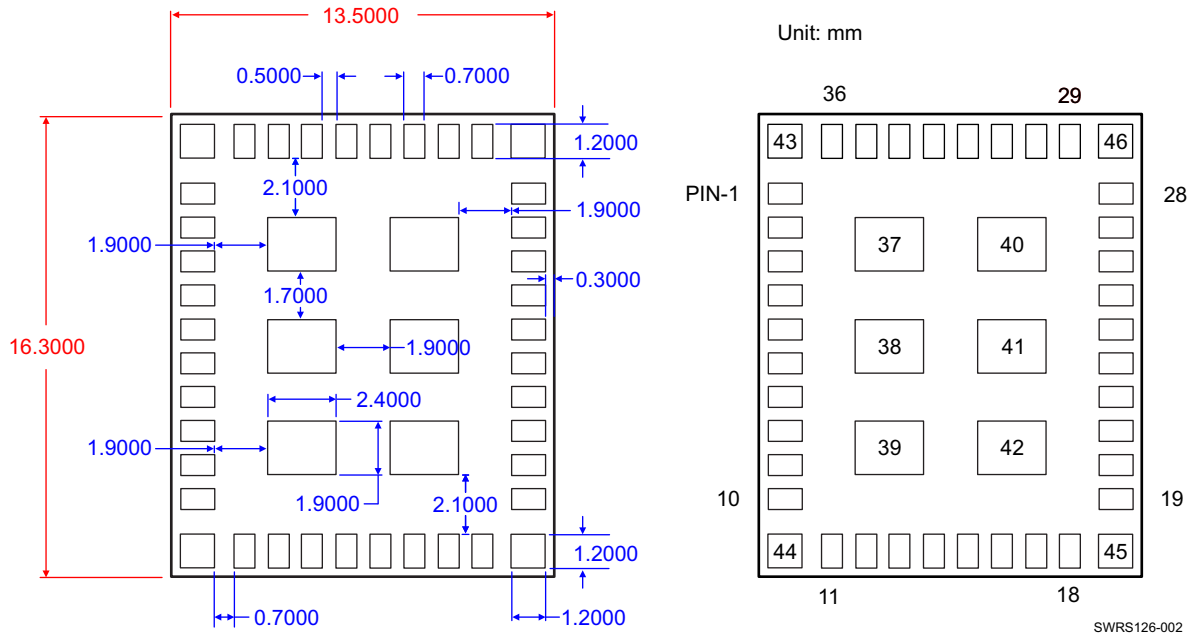

**Figure 2. CC3000 Module Footprint and Pinouts**

**Pin Description**

Table 1 describes the CC3000 module pins.

**Table 1. CC3000 Module Pins Description**

Pin	Signal Name	Type	State at Reset	State After Reset	Voltage Level	Description
1	GND	GND	—	—	—	Ground
2	Reserved_1	—	—	—	1.8 V	Reserved. Connect to test point.
3	NC	—	—	—	—	Not connected
4	Reserved_2	—	—	—	1.8 V	Reserved. Connect to test point.
5	WL_EN2 <sup>(1)</sup>	I	Hi-Z	—	—	Mode setting
6	WL_RS232_TX <sup>(2)</sup>	O	Hi-Z	Force 1	1.8 V	RS232 test-mode signal (1.8-V logic). Connect to test point. Serial connection for CC3000 radio tool.
7	WL_EN1	I	Hi-Z	—	—	Mode setting
8	WL_RS232_RX <sup>(2)</sup>	I	Hi-Z	PU	1.8 V	RS232 test-mode signal (1.8-V logic). Connect to test point. Serial connection for CC3000 radio tool.
9	GND	GND	—	—	—	Ground
10	GND	GND	—	—	—	Ground
11	GND	GND	—	—	—	Ground
12	SPI_CS	I	Hi-Z	PU	VIO_HOST	Host interface SPI chip-select (CS)
13	SPI_DOUT	O	Hi-Z	PU	VIO_HOST	Host interface SPI data out
14	SPI_IRQ	O	Hi-Z	Force 1	VIO_HOST	Host interface SPI interrupt

(1) Connect WL\_EN1 to WL\_EL2 for proper operation of the module.

(2) Leave unconnected in function module.

**Table 1. CC3000 Module Pins Description (continued)**

Pin	Signal Name	Type	State at Reset	State After Reset	Voltage Level	Description
15	SPI_DIN	I	Hi-Z	PU	VIO_HOST	Host interface SPI data in
16	GND	GND	—	—	—	Ground
17	SPI_CLK	I	Hi-Z	PD	VIO_HOST	Host interface SPI clock
18	GND	GND	—	—	—	Ground
19	VBAT_IN	Power	—	—	V <sub>BAT</sub>	Power supply input, 2.7 to 4.8 V
20	GND	GND	—	—	—	Ground
21	EXT_32K	—	—	—	—	Not used. Connect to ground.
22	GND	GND	—	—	—	Ground
23	VIO_HOST	Power	—	—	VIO_HOST	VIO host supply voltage
24	Reserved 3	—	—	—	—	Reserved. Connect to test point.
25	GND	GND	—	—	—	Ground
26	VBAT_SW_EN	I	—	—	VIO_HOST	Module enable. Connect to host GPIO.
27	SDA_EEPROM <sup>(3)</sup>	I/O			1.8 V	I2C data line from EEPROM
28	SDA_CC3000 <sup>(3)</sup>	I/O			1.8 V	I2C data line from the CC3000 module
29	SCL_EEPROM <sup>(4)</sup>	I/O			1.8 V	I2C clock line from EEPROM
30	SCL_CC3000 <sup>(4)</sup>	I/O			1.8 V	I2C clock line from the CC3000 module
31	GND	GND	—	—	—	Ground
32	GND	GND	—	—	—	Ground
33	GND	GND	—	—	—	Ground
34	GND	GND	—	—	—	Ground
35	RF_ANT	RF	—	—	—	WLAN antenna port, 50-Ω single
36	GND	GND	—	—	—	Ground
37	GND	GND	—	—	—	Ground
38	GND	GND	—	—	—	Ground
39	GND	GND	—	—	—	Ground
40	GND	GND	—	—	—	Ground
41	GND	GND	—	—	—	Ground
42	GND	GND	—	—	—	Ground
43	GND	GND	—	—	—	Ground
44	GND	GND	—	—	—	Ground
45	GND	GND	—	—	—	Ground
46	GND	GND	—	—	—	Ground

(3) Connect SDA\_EEPROM and SDA\_CC3000 through a 0-Ω resistor.

(4) Connect SCL\_EEPROM and SCL\_CC3000 through a 0-Ω resistor.

## ESD PERFORMANCE

Because electrostatic discharge (ESD) can damage this integrated circuit, TI recommends handling all integrated circuits (ICs) with appropriate precautions. Failure to observe proper handling and installation procedures can cause damage. ESD damage can range from subtle performance degradation to complete device failure. Precision ICs can be more susceptible to damage because very small parametric changes can cause devices not to meet their published specifications.

Table 2 describes the ESD performance.

**Table 2. ESD Performance**

HDM <sup>(1)</sup>	CDM <sup>(2)</sup>
1000 V	500 V

(1) JEDEC ESD HBM spec JS-001-2012

(2) JEDEC ESD CDM spec 22C101E

## MODULE SPECIFICATIONS

### Absolute Maximum Ratings

Parameters	Pin	Min	Max	Unit
VBAT_IN	19	-0.5	+6.0	V
VIO_HOST	23	-0.5	+4.6	V
I2C and WL_RS232	27, 28, 29, 30, 6, 8	-0.5	+2.1	V
SPI interface	12, 13, 14, 15, 17	-0.5	+4.6	V
VBAT_SW_EN	26	-0.3	+6.0	V
Storage temperature range	–	-40	+85	°C

### Recommended Operating Conditions

Rating	Condition	Sym	Min	Max	Unit
Operating ambient temperature			-20	+70	°C
VBAT_IN			2.7	4.8	V
VIO_HOST supply voltage			1.8	3.6	V
<b>SPI interface</b>					
High-level input voltage	VIO_HOST =	VIH	1.8 to 1.95 V	VIO_HOST x 0.65	V
			1.95 to 2.7 V	1.6	
			2.7 to 3.6 V	2	
Low-level input voltage	VIO_HOST =	VIL	1.8 to 1.95 V	VIO_HOST x 0.35	V
			1.95 to 2.7 V	0.7	
			2.7 to 3.6 V	0.8	
Input voltage		VI	0	3.6	V
Output voltage	Active state	VO	0	VIO_HOST	V
Input transition rise or fall rate		$\Delta t/\Delta v$		5	ns/V
<b>VBAT SW EN</b>					
High-level input voltage		VIH	1.1	5.5	V
Low-level input voltage		VIL	0	0.4	V

## Power Consumption

Parameters	Test Conditions	Typ	Max	Unit
802.11b TX current	VBAT = 3.6 V Tamb = +25°C Po = 18 dBm, 11 Mbps L = 2048 bytes tdelay (idle) = 40 μs	260	275	mA
802.11g TX current	VBAT = 3.6 V Tamb = +25°C Po = 14 dBm, 54 Mbps L = 2048 tdelay (idle) = 40 μs	190	207	mA
802.11bg RX current	VBAT = 3.6 V	92	103	mA
Shut-down mode	VBAT = 3.6 V VBAT_SW_EN = 0 V		5	μA

## WLAN Transmitter RF Characteristics

(TA = +25°C, VBAT = 3.6 V)

Characteristics	Condition (Mbps)	Min	Typ	Max	Unit
Maximum RMS output power	1		18.3		dBm
	2		18.2		
	11		18.1		
	6		17.0		
	9		17.0		
	18		17.0		
	36		15.5		
	54		14.0		
In-band power variation				±1	
Transmit center frequency accuracy				±20	ppm

## Receiver RF Characteristics

(TA = +25°C, VBAT = 3.6 V)

Characteristics	Condition (Mbps)	Min	Typ	Max	Unit
Sensitivity	1 DSSS		-97.5		dBm
	2 DSSS		-95.0		
	11 CCK		-89.0		
	6 OFDM		-91.0		
	9 OFDM		-91.0		
	18 OFDM		-87.0		
	36 OFDM		-81.0		
	54 OFDM		-75.0		
Maximum input level	802.11b			-10	dBm
	802.11g			-20	

## SPI HOST CONTROLLER INTERFACE

The SPI is the primary host interface to the CC3000 module.

The SPI interface contains the five-line, master and slave communication model shown in [Figure 3](#).

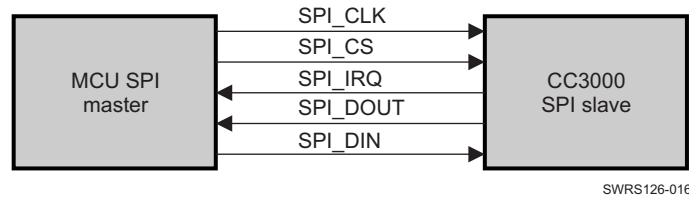

Figure 3. SPI Host Connectivity

[Table 3](#) highlights the CC3000 SPI pin names and functions.

Table 3. SPI Line Description

Pin Name	Description
SPI_CLK	Clock (0 to 16 MHz) from host to slave
SPI_CS <sup>(1)</sup>	CS (active low) signal from host to slave
SPI_DIN	Data from host to slave
SPI_IRQ <sup>(2)</sup>	Interrupt from slave to host
SPI_DOUT	Data from slave to host

(1) SPI\_CS selects a CC3000 module, indicating that a master wants to communicate to the device.

(2) SPI\_IRQ is a dual-purpose slave to the master direction line: in SPI IDLE state while no data transfer is active, driving SPI\_IRQ low indicates to the master that the CC3000 module has data to pass to it; driving SPI\_IRQ low following SPI\_CS deassertion indicates that the CC3000 module is ready to receive data.

## SPI Timing

[Figure 4](#) shows the SPI timing sequence.

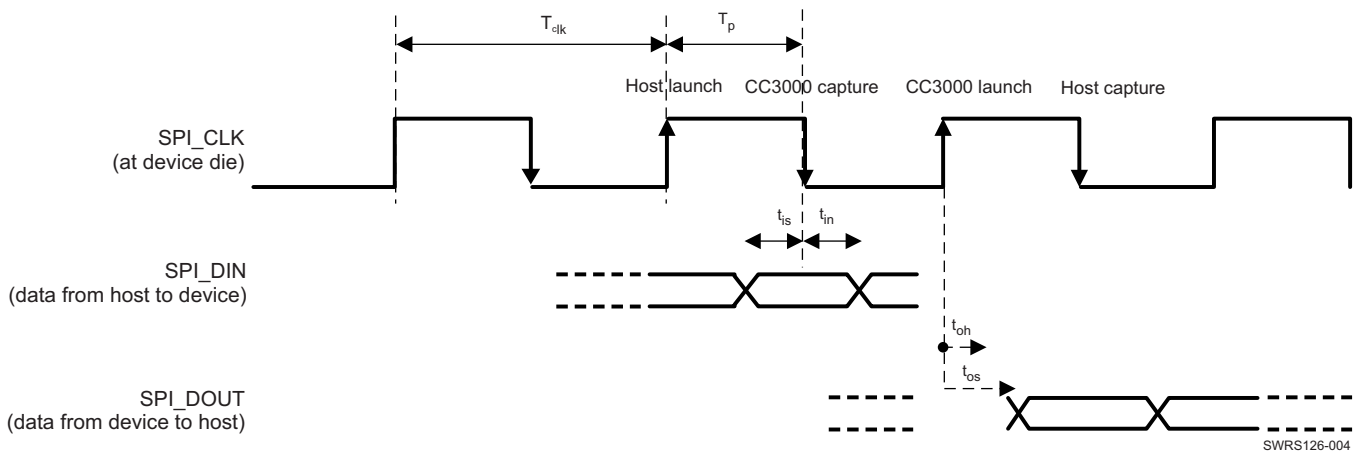

Figure 4. SPI Timing Sequence

Table 4 lists the SPI timing parameters.

**Table 4. SPI Timing Parameters**

Symbol	Parameter <sup>(1)(2)</sup>	Min	Max	Unit
$T_{clk}$	Clock period	62.5		ns
$T_p$	High pulse width (including jitter and duty cycle)	25 <sup>(3)</sup>	37.5 <sup>(3)</sup>	ns
$t_{is}$	RX setup time; minimum time in which data is stable before capture edge	5		ns
$t_{ih}$	RX hold time; minimum time in which data is stable after capture edge	5		
$t_{os}$	TX setup propagation time; maximum time from launch edge until data is stable		10.2	
$t_{oh}$	TX hold propagation time; minimum time of data stable after launch edge	3		
$C_L$	Capacitive load on interface		20	pF

- (1) The SPI\_CS signal is considered to be asynchronous.  
 (2) In this example, launch is on the rising edge, and capture is on the falling edge. The opposite scheme can be configured.  
 (3) 40% to 60% DC (valid for the minimum clock period)

## POWER-UP SEQUENCE

Figure 5 demonstrates the wake-up sequence of the CC3000 module.

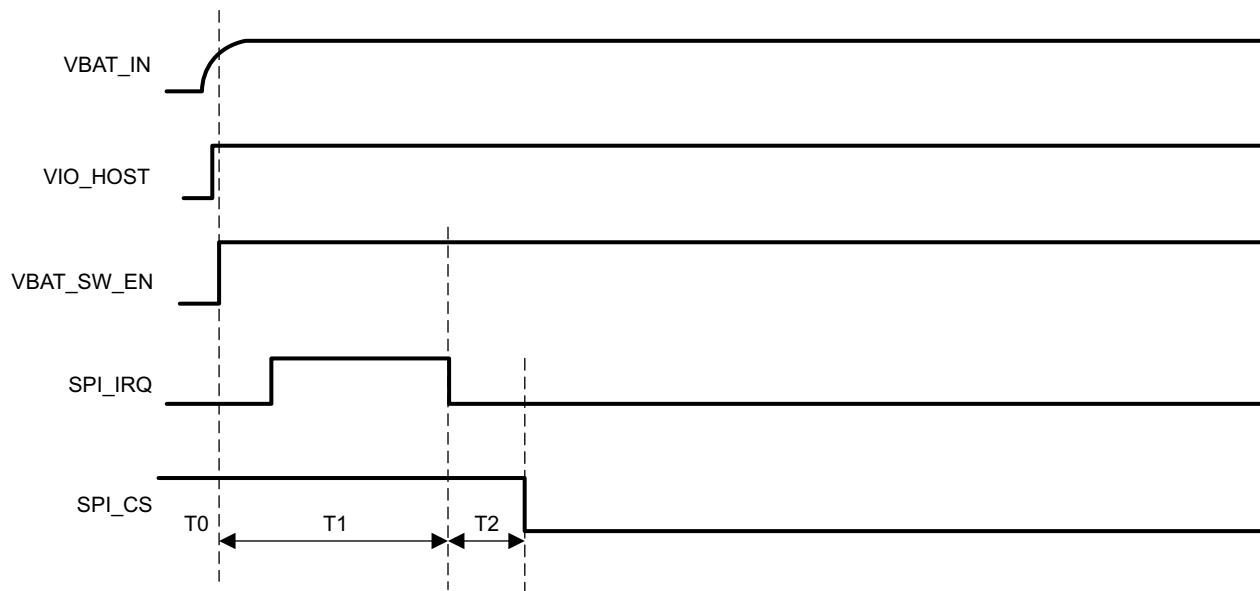

SWRS126-005

Figure 5. CC3000 Module Power-On Sequences

### NOTE

- VBAT\_IN and VIO\_HOST must be available before VBAT\_SW\_EN is asserted.
- At wake-up time (T1): The CC3000 module powers up after SPI\_IRQ changes state to LOW. T1 is approximately 53 ms.
- At T2: The normal master SPI write sequence is SPI\_CS low, followed by SPI\_IRQ low (CC3000 host), indicating that the CC3000 core module is ready to accept data. T2 duration is approximately 7 ms.

## CC3000 Enable Pins Configuration

Table 5 describes the CC3000 mode of operation based on the enable (EN) pins setting.

Table 5. CC3000 EN Pins Configuration

Mode	State
Test mode <sup>(1)</sup>	WL_EN1: Leave disconnected. WL_EN2: Connect to ground.
Functional mode <sup>(2)</sup>	WL_EN1 and WL_EN2 are shorted together.

(1) For CC3000 radio tool operation

(2) For normal operation

### Test Mode Serial Interface

The CC3000 module contains a dedicated WLAN serial interface to connect to the CC3000 radio tests tool, an external PC-based software test utility, during development and evaluation phase (see Figure 6 and Table 6). The CC3000 radio test tool utility can be obtained from the CC3000 TI wiki ([www.ti.com/connectivitywiki](http://www.ti.com/connectivitywiki)).

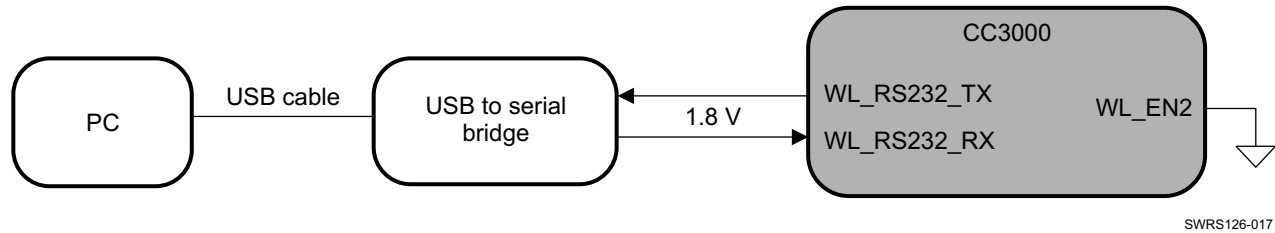

Figure 6. CC3000 Test Mode Serial Interface Connection

Table 6. CC3000 Test Mode Debug Interface Description

Signal Name	Function
WL_RS232_TX	Connection with CC3000 radio PC-based software <sup>(1)</sup>
WL_RS232_RX	

(1) WL\_EN2 pins must be grounded while bringing up the CC3000 radio tool.

### SURFACE MOUNT INFORMATION

The CC3000 module uses a flat shield cover designed for a fully automated assembly process. For baking and reflow recommendations, follow MSL level 4 found in the JEDEC/IPC Standard J-STD-20b. The classification temperature (T<sub>C</sub>) for the module is 250°C.

### MECHANICAL INFORMATION

#### Module Mechanical Outline

Figure 7 shows the mechanical outline for the CC3000 module.

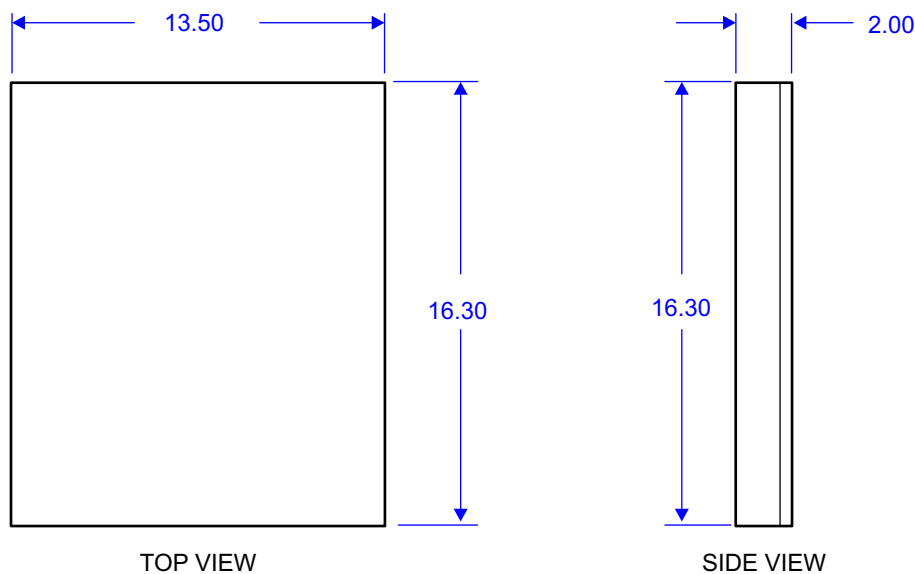

CC3000MOD  
Module Size: 16.3 x 13.5 x 2.0 mm

SWRS126-007

Figure 7. CC3000 Module Mechanical Outline

## Package Marking

Figure 8 shows the CC3000 module package marking.

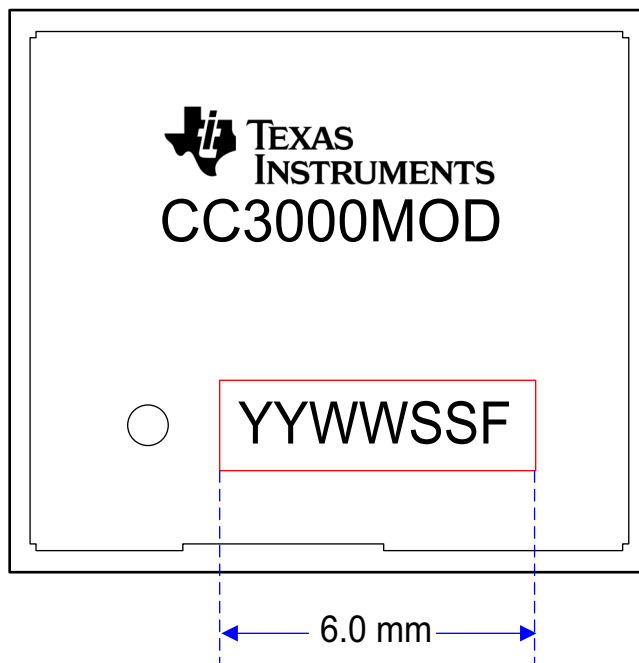

SWRS126-008

Figure 8. CC3000 Module Package Marking

Table 7 defines the marking code.

Table 7. Package Marking Definitions

Code	Definition
YYWWSSF	Date
YY	Year (for example, 2012 = 12)
WW	Week (01 through 53)
SS	Serial number from 01 to 99 to match manufacturer lot number
F	Reserved for internal use

## Ordering Information

Table 8 lists the CC3000 module part numbers.

Table 8. CC3000 Module Part Numbers

Order Number	Description
CC3000MOD	CC3000 module, 44 modules per tray
CC3000MODR	CC3000 module reel, 1200 modules per reel

REFERENCE SCHEMATICS AND BILL OF MATERIALS

Figure 9 shows the schematics for the CC3000 to host reference design.

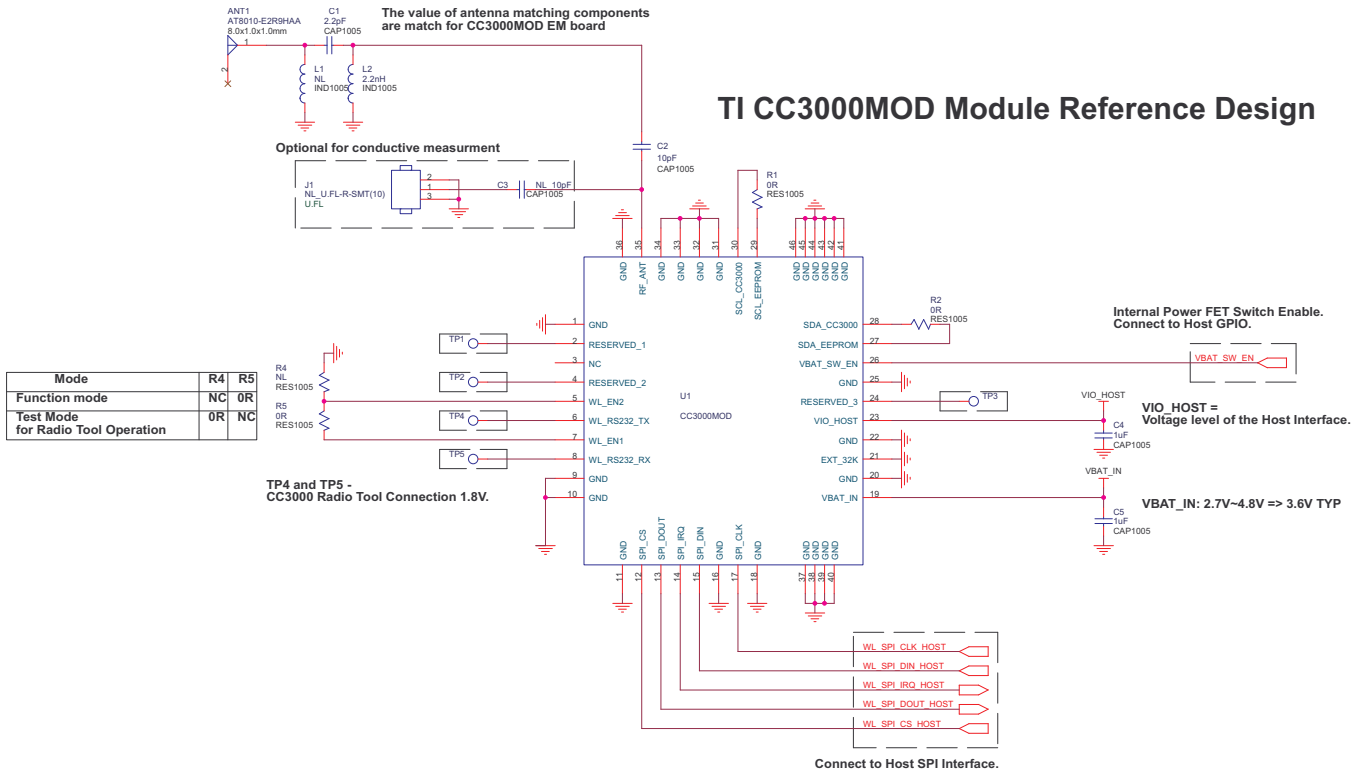

Figure 9. CC3000 Module to Host Reference Design

NOTE

For flexibility, VIO\_HOST supports both cases in which the VBAT and VIO voltages of the MCU can be the same or different.

Table 9 lists the bill of materials.

Table 9. Bill of Materials

Part Reference	Description	Manufacturer	Manufacturer PN
ANT1	2.4-GHz chip antenna, 8.0 × 1.0 mm	ACX	AT8010-E2R9HAA
C1	C0402, 2.2 pF	Walsin	0402N2R2C500LT
L2	L0402, 2.2 nH	ACX	HI1005-1C2N2SMT
C2 <sup>(1)</sup>	C0402, 10 pF	Walsin	0402N100J500LT
C4, C5 <sup>(1)</sup>	C0402, 1 µF	Murata	GRM155R60J105KE19D
R1, R2, R5 <sup>(1)</sup>	R0402, 0R	Walsin	WR04X000PTL
J1	RF coaxial U.F.L, SMD	Hirose	U.FL-R-SMT-1(10)

(1) Any component with similar values can be used.

## DESIGN RECOMMENDATIONS

This section describes the layout recommendations for the CC3000 module, RF trace, and antenna.

### Antenna

The ACX ceramic antenna is mounted on the CC3000 EVM board with a specific layout and matching circuit for the radiation test conducted in FCC, CE and IC certifications. Figure 10 shows the location of the antenna on the EVM board as well as the RF trace routing from the CC3000 module.

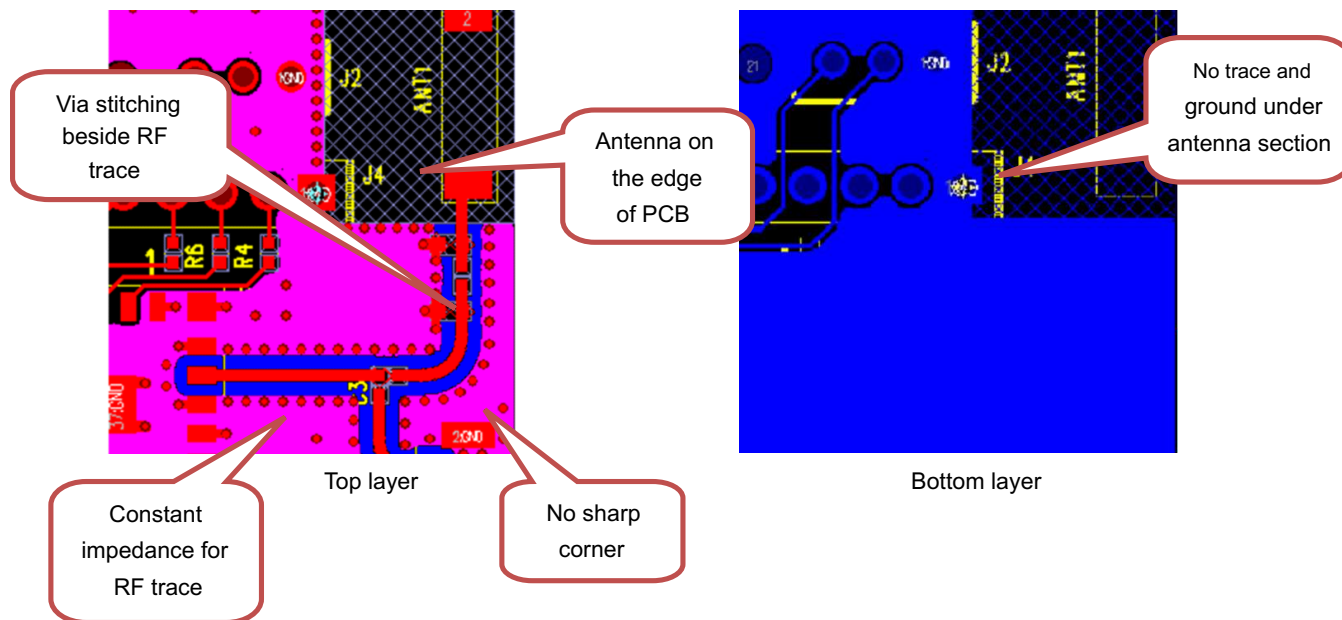

SWRS126-015

Figure 10. RF Trace and Antenna Design for PCB Layout

### Module Layout Recommendations

Observe the following module layout recommendations (see also Figure 11):

- Have a solid ground plane and ground vias under the module for stable system and thermal dissipation.
- Do not run signal traces underneath the module on a layer where the module is mounted.
- Signal traces can be run on a third layer under the solid ground layer and beneath the module mounting layer.

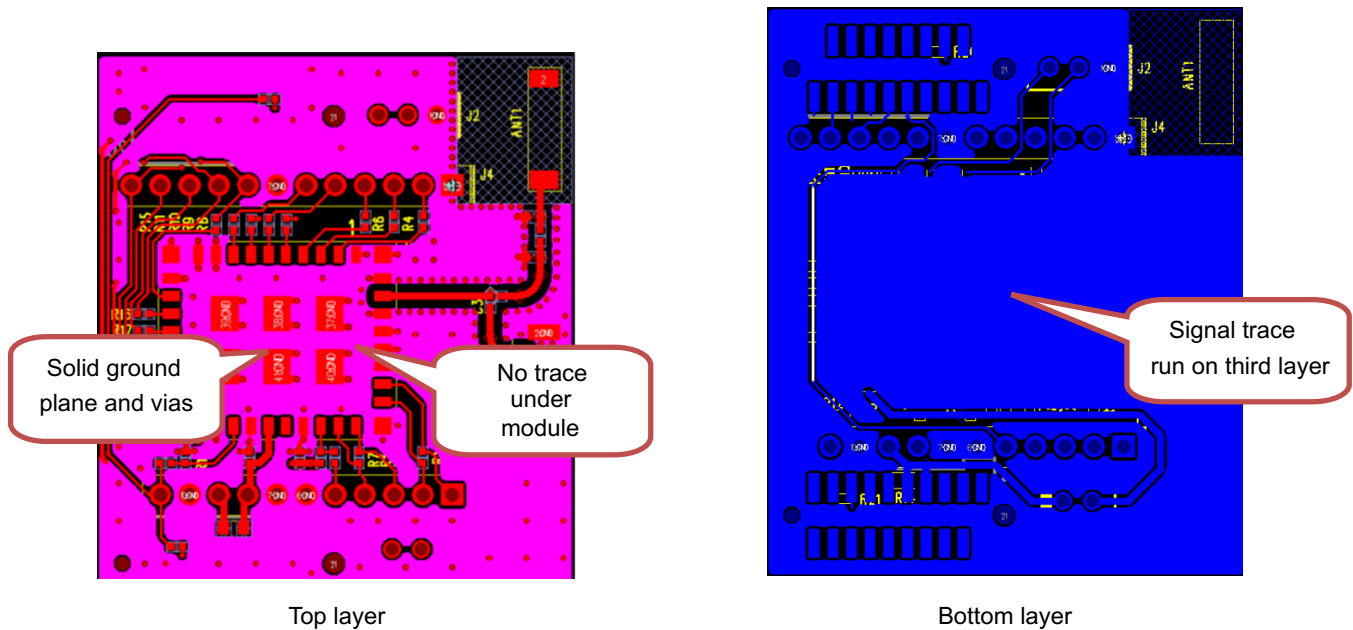

SWRS126-014

Figure 11. Module Layout

### RF Trace and Antenna Layout Recommendations

Observe the following recommendations for RF trace and antenna layout (see also [Figure 10](#)):

- RF traces must have 50- $\Omega$  impedance (microstrip transmission line).
- RF trace bends must be gradual with a maximum bend of approximately 45 degrees and with trace mitered. RF traces must not have sharp corners.
- There must be no traces or ground under the antenna section.
- RF traces must have via stitching on the ground plane beside the RF trace on both sides.
- RF traces must be as short as possible. The antenna, RF traces, and the module must be on the edge of the PCB product in consideration of the product enclosure material and proximity.

**PACKAGING INFORMATION**

Orderable Device	Status (1)	Package Type	Package Drawing	Pins	Package Qty	Eco Plan (2)	Lead/Ball Finish (6)	MSL Peak Temp (3)	Op Temp (°C)	Device Marking (4/5)	Samples
CC3000MOD	NRND			46		TBD	Call TI	Call TI	-20 to 70		
CC3000MODR	NRND			46		TBD	Call TI	Call TI	-20 to 70		
CC3000MODT	NRND			46		TBD	Call TI	Call TI			
CC3000YFVR	NRND	DSBGA	YFV	126		Green (RoHS & no Sb/Br)	SNAGCU	Level-1-260C-UNLIM		CC3000	
CC3000YFVT	NRND	DSBGA	YFV	126		TBD	Call TI	Call TI		CC3000	
XCC3000MOD	OBSOLETE			46		TBD	Call TI	Call TI	-20 to 70		

(1) The marketing status values are defined as follows:

**ACTIVE:** Product device recommended for new designs.

**LIFEBUY:** TI has announced that the device will be discontinued, and a lifetime-buy period is in effect.

**NRND:** Not recommended for new designs. Device is in production to support existing customers, but TI does not recommend using this part in a new design.

**PREVIEW:** Device has been announced but is not in production. Samples may or may not be available.

**OBSOLETE:** TI has discontinued the production of the device.

(2) Eco Plan - The planned eco-friendly classification: Pb-Free (RoHS), Pb-Free (RoHS Exempt), or Green (RoHS & no Sb/Br) - please check <http://www.ti.com/productcontent> for the latest availability information and additional product content details.

**TBD:** The Pb-Free/Green conversion plan has not been defined.

**Pb-Free (RoHS):** TI's terms "Lead-Free" or "Pb-Free" mean semiconductor products that are compatible with the current RoHS requirements for all 6 substances, including the requirement that lead not exceed 0.1% by weight in homogeneous materials. Where designed to be soldered at high temperatures, TI Pb-Free products are suitable for use in specified lead-free processes.

**Pb-Free (RoHS Exempt):** This component has a RoHS exemption for either 1) lead-based flip-chip solder bumps used between the die and package, or 2) lead-based die adhesive used between the die and leadframe. The component is otherwise considered Pb-Free (RoHS compatible) as defined above.

**Green (RoHS & no Sb/Br):** TI defines "Green" to mean Pb-Free (RoHS compatible), and free of Bromine (Br) and Antimony (Sb) based flame retardants (Br or Sb do not exceed 0.1% by weight in homogeneous material)

(3) MSL, Peak Temp. - The Moisture Sensitivity Level rating according to the JEDEC industry standard classifications, and peak solder temperature.

(4) There may be additional marking, which relates to the logo, the lot trace code information, or the environmental category on the device.

(5) Multiple Device Markings will be inside parentheses. Only one Device Marking contained in parentheses and separated by a "~" will appear on a device. If a line is indented then it is a continuation of the previous line and the two combined represent the entire Device Marking for that device.

(6) Lead/Ball Finish - Orderable Devices may have multiple material finish options. Finish options are separated by a vertical ruled line. Lead/Ball Finish values may wrap to two lines if the finish value exceeds the maximum column width.

**Important Information and Disclaimer:**The information provided on this page represents TI's knowledge and belief as of the date that it is provided. TI bases its knowledge and belief on information provided by third parties, and makes no representation or warranty as to the accuracy of such information. Efforts are underway to better integrate information from third parties. TI has taken and continues to take reasonable steps to provide representative and accurate information but may not have conducted destructive testing or chemical analysis on incoming materials and chemicals. TI and TI suppliers consider certain information to be proprietary, and thus CAS numbers and other limited information may not be available for release.

In no event shall TI's liability arising out of such information exceed the total purchase price of the TI part(s) at issue in this document sold by TI to Customer on an annual basis.

## TAPE AND REEL INFORMATION

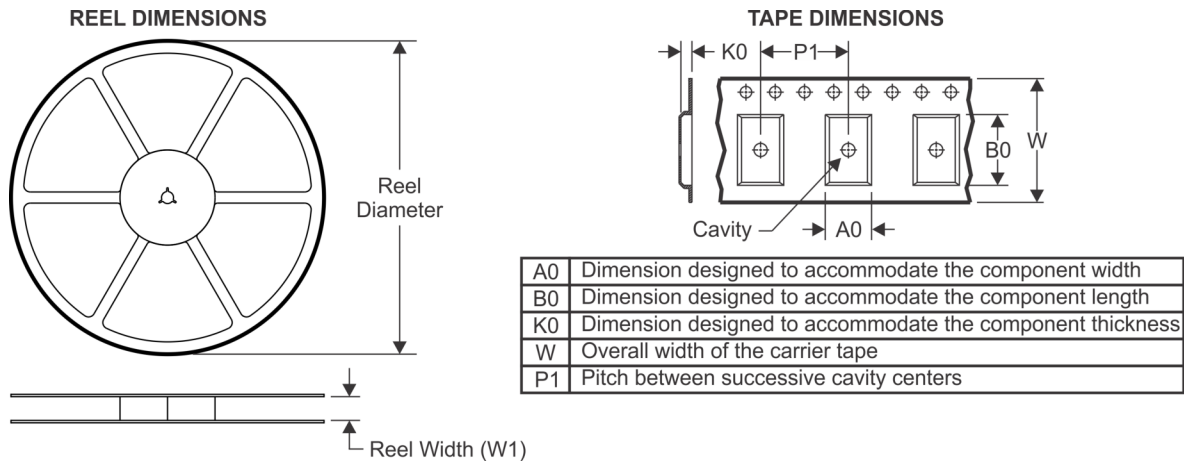

### QUADRANT ASSIGNMENTS FOR PIN 1 ORIENTATION IN TAPE

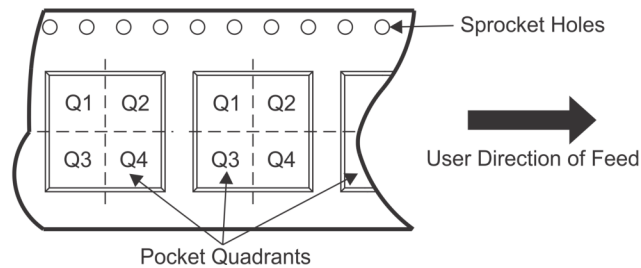

\*All dimensions are nominal

Device	Package Type	Package Drawing	Pins	SPQ	Reel Diameter (mm)	Reel Width W1 (mm)	A0 (mm)	B0 (mm)	K0 (mm)	P1 (mm)	W (mm)	Pin1 Quadrant
CC3000YFVR	DSBGA	YFV	126	0	330.0	12.4	4.7	5.16	0.7	8.0	12.0	Q1

TAPE AND REEL BOX DIMENSIONS



\*All dimensions are nominal

Device	Package Type	Package Drawing	Pins	SPQ	Length (mm)	Width (mm)	Height (mm)
CC3000YFVR	DSBGA	YFV	126	0	367.0	367.0	35.0

## IMPORTANT NOTICE

Texas Instruments Incorporated and its subsidiaries (TI) reserve the right to make corrections, enhancements, improvements and other changes to its semiconductor products and services per JESD46, latest issue, and to discontinue any product or service per JESD48, latest issue. Buyers should obtain the latest relevant information before placing orders and should verify that such information is current and complete. All semiconductor products (also referred to herein as "components") are sold subject to TI's terms and conditions of sale supplied at the time of order acknowledgment.

TI warrants performance of its components to the specifications applicable at the time of sale, in accordance with the warranty in TI's terms and conditions of sale of semiconductor products. Testing and other quality control techniques are used to the extent TI deems necessary to support this warranty. Except where mandated by applicable law, testing of all parameters of each component is not necessarily performed.

TI assumes no liability for applications assistance or the design of Buyers' products. Buyers are responsible for their products and applications using TI components. To minimize the risks associated with Buyers' products and applications, Buyers should provide adequate design and operating safeguards.

TI does not warrant or represent that any license, either express or implied, is granted under any patent right, copyright, mask work right, or other intellectual property right relating to any combination, machine, or process in which TI components or services are used. Information published by TI regarding third-party products or services does not constitute a license to use such products or services or a warranty or endorsement thereof. Use of such information may require a license from a third party under the patents or other intellectual property of the third party, or a license from TI under the patents or other intellectual property of TI.

Reproduction of significant portions of TI information in TI data books or data sheets is permissible only if reproduction is without alteration and is accompanied by all associated warranties, conditions, limitations, and notices. TI is not responsible or liable for such altered documentation. Information of third parties may be subject to additional restrictions.

Resale of TI components or services with statements different from or beyond the parameters stated by TI for that component or service voids all express and any implied warranties for the associated TI component or service and is an unfair and deceptive business practice. TI is not responsible or liable for any such statements.

Buyer acknowledges and agrees that it is solely responsible for compliance with all legal, regulatory and safety-related requirements concerning its products, and any use of TI components in its applications, notwithstanding any applications-related information or support that may be provided by TI. Buyer represents and agrees that it has all the necessary expertise to create and implement safeguards which anticipate dangerous consequences of failures, monitor failures and their consequences, lessen the likelihood of failures that might cause harm and take appropriate remedial actions. Buyer will fully indemnify TI and its representatives against any damages arising out of the use of any TI components in safety-critical applications.

In some cases, TI components may be promoted specifically to facilitate safety-related applications. With such components, TI's goal is to help enable customers to design and create their own end-product solutions that meet applicable functional safety standards and requirements. Nonetheless, such components are subject to these terms.

No TI components are authorized for use in FDA Class III (or similar life-critical medical equipment) unless authorized officers of the parties have executed a special agreement specifically governing such use.

Only those TI components which TI has specifically designated as military grade or "enhanced plastic" are designed and intended for use in military/aerospace applications or environments. Buyer acknowledges and agrees that any military or aerospace use of TI components which have **not** been so designated is solely at the Buyer's risk, and that Buyer is solely responsible for compliance with all legal and regulatory requirements in connection with such use.

TI has specifically designated certain components as meeting ISO/TS16949 requirements, mainly for automotive use. In any case of use of non-designated products, TI will not be responsible for any failure to meet ISO/TS16949.

### Products

Audio	<a href="http://www.ti.com/audio">www.ti.com/audio</a>
Amplifiers	<a href="http://amplifier.ti.com">amplifier.ti.com</a>
Data Converters	<a href="http://dataconverter.ti.com">dataconverter.ti.com</a>
DLP® Products	<a href="http://www.dlp.com">www.dlp.com</a>
DSP	<a href="http://dsp.ti.com">dsp.ti.com</a>
Clocks and Timers	<a href="http://www.ti.com/clocks">www.ti.com/clocks</a>
Interface	<a href="http://interface.ti.com">interface.ti.com</a>
Logic	<a href="http://logic.ti.com">logic.ti.com</a>
Power Mgmt	<a href="http://power.ti.com">power.ti.com</a>
Microcontrollers	<a href="http://microcontroller.ti.com">microcontroller.ti.com</a>
RFID	<a href="http://www.ti-rfid.com">www.ti-rfid.com</a>
OMAP Applications Processors	<a href="http://www.ti.com/omap">www.ti.com/omap</a>
Wireless Connectivity	<a href="http://www.ti.com/wirelessconnectivity">www.ti.com/wirelessconnectivity</a>

### Applications

Automotive and Transportation	<a href="http://www.ti.com/automotive">www.ti.com/automotive</a>
Communications and Telecom	<a href="http://www.ti.com/communications">www.ti.com/communications</a>
Computers and Peripherals	<a href="http://www.ti.com/computers">www.ti.com/computers</a>
Consumer Electronics	<a href="http://www.ti.com/consumer-apps">www.ti.com/consumer-apps</a>
Energy and Lighting	<a href="http://www.ti.com/energy">www.ti.com/energy</a>
Industrial	<a href="http://www.ti.com/industrial">www.ti.com/industrial</a>
Medical	<a href="http://www.ti.com/medical">www.ti.com/medical</a>
Security	<a href="http://www.ti.com/security">www.ti.com/security</a>
Space, Avionics and Defense	<a href="http://www.ti.com/space-avionics-defense">www.ti.com/space-avionics-defense</a>
Video and Imaging	<a href="http://www.ti.com/video">www.ti.com/video</a>

### TI E2E Community

[e2e.ti.com](http://e2e.ti.com)